

User manual and parts handbook

Blec Bar grader 180 - 240

Serial number:

REDEXIM

Kwekerijweg 8
3709 JA Zeist
the Netherlands
T: (31)30 6933227
F: (31)30 6933228
E: verti-drain@redexim.com
www.redexim.com

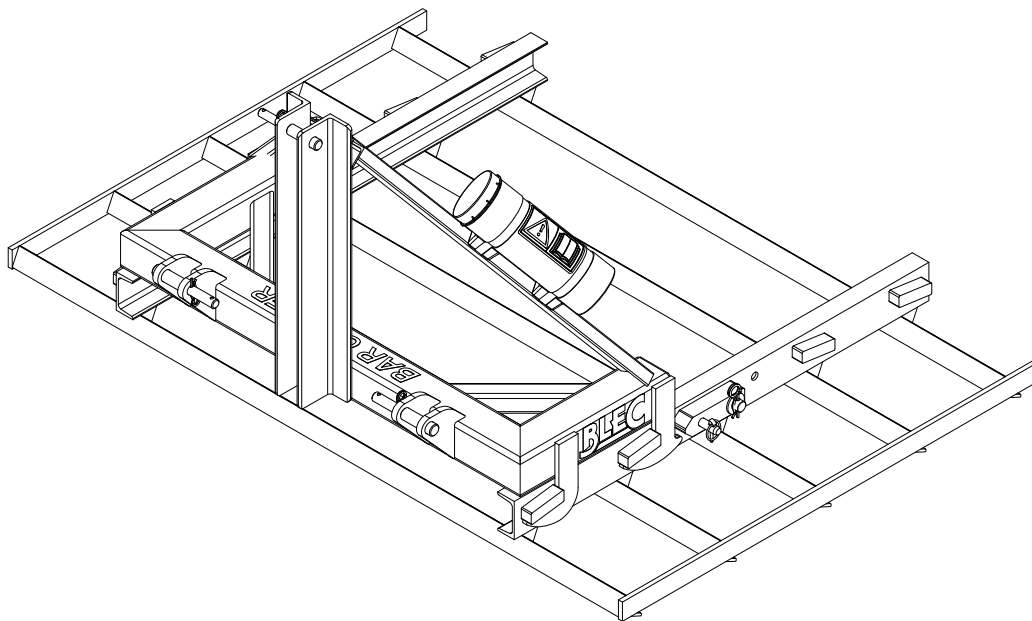
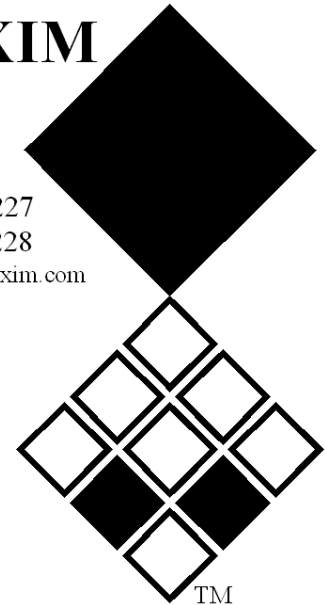

ATTENTION:
TO ENSURE SAFE USE OF THIS MACHINE AND TO BE ABLE TO ACHIEVE THE BEST RESULTS, IT IS OF THE UTMOST IMPORTANCE TO READ THIS USER MANUAL THOROUGHLY BEFORE USING THE BAR GRADER.



FOREWORD

Congratulations on your purchase of the BAR GRADER. To ensure the long and safe use of this BAR GRADER, it is of the utmost importance for all those who will be using it to read and understand this user manual.

Operation of this machine is not safe without full knowledge of the contents of the manual.

The BAR GRADER is not an independently operating machine. The user is responsible for using the appropriate tractor. The user must also check the tractor/BAR GRADER combination for safety aspects, such as the noise level, adequate user instructions and possible risk factors.

On the next page, you will first find the general safety instructions. Every user must know and apply them. After this, a registration card is included. This card should be returned for handling any future claims.

This user manual offers many instructions numbered in sequence. This sequence should be observed. An  indicates a safety instruction. An  indicates a tip and/or note. All information and technical specifications provided at the moment that this document is published are the most recent ones. Design specifications may be changed without prior notice.

This document is a translation of the original operating instructions. Upon request, the original operating instructions are available in Dutch.

GUARANTEE CONDITIONS

THIS BAR GRADER IS DELIVERED WITH A WARRANTY AGAINST DEFECTS IN MATERIALS. THIS GUARANTEE IS VALID FOR A PERIOD OF 12 MONTHS FROM THE PURCHASE DATE. BAR GRADER WARRANTIES ARE SUBJECT TO THE "GENERAL CONDITIONS FOR SUPPLY OF PLANT AND MACHINERY FOR EXPORT, NUMBER 188", WHICH ARE PUBLISHED UNDER THE AUSPICES OF THE UNITED NATIONS ECONOMIC COMMISSION FOR EUROPE.

REGISTRATION CARD

For your own information, please complete the table below:

Serial number of machine	
Dealer's name	
Purchase date	
Remarks	

! SAFETY INSTRUCTIONS !

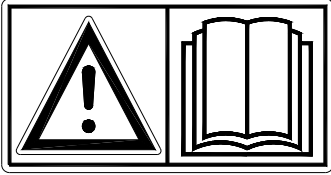
 <p>Fig. 1</p>	<p>The BAR GRADER is designed for safe use. However, this is only possible if the user fully observes the safety instructions given in this manual.</p> <p>Read and understand (Fig. 1) the manual before starting to use the BAR GRADER. If the machine is not used as described in the manual, injury and/or damage to the BAR GRADER may result.</p>
---	--

1. The machine must only be used by professionals and must first be professionally adjusted for use on the ground that is to be treated.

The manufacturer does not accept any liability with regard to damage resulting from non-professional use; all resulting risks are the responsibility of the user. Correct/professional use also includes following the manufacturer's instructions for use, maintenance and repair.

Before using the BAR GRADER, inspect the area to be treated.

2. The BAR GRADER is constructed according to the latest technological knowledge and is safe to use.

Improper use, maintenance or repair of the machine may result in injury to both the user and others. **This must be avoided!**

Always use the BAR GRADER in combination with the proper tractor, as described in the technical data.

3. All persons whom the owner assigns to operate, maintain or repair the BAR GRADER must read and have completely understood the operating manual and in particular the **Safety Instructions** section.

The user is responsible for a **safe tractor/BAR GRADER combination. This unit must be tested** in terms of noise, safety and ease-of-use. In addition, user's instructions must be prepared.

4. Before using the BAR GRADER, the user is **obliged** to inspect it for **visible damage and defects**.

Any changes to the BAR GRADER (including its functioning) that may affect its safety must be corrected immediately.

For reasons of safety, it is in principle forbidden to make changes or additions to the BAR GRADER (with the exception of those approved by the manufacturer).

If any **modifications** are made to the BAR GRADER, the present CE certificate becomes null and void and the person who made the modifications must **himself** make sure a new **CE certificate** is granted.

Before each use, inspect the BAR GRADER for loose bolts/nuts/parts.

NEVER use de BAR GRADER if its protective covers and safety stickers are missing.

NEVER crawl underneath the BAR GRADER.

If you need to access the bottom, tilt the BAR GRADER.

NEVER step off the tractor while the engine is still running.

When carrying out maintenance, adjustments or repairs, make sure the BAR GRADER is blocked from sagging/moving/sliding.

Before carrying out maintenance, adjustments and repairs **always first switch off the tractor motor and remove the tractor key from the ignition** (Fig. 4).



Fig. 2

Use only original BAR GRADER parts for maintenance or repairs.

This will ensure continued safety of the machine and its user.

Only authorised technical personnel may carry out adjustments and repair work on the BAR GRADER.

Keep an overview of repairs.

5. In addition to the instructions in this user manual, the generally applicable regulations with respect to safety and working conditions must be observed.

The relevant traffic rules also apply to use on public roads.

Transporting persons is not permitted!

Do not use the BAR GRADER when it is dark, during heavy rain/storms, or on slopes with a gradient greater than 20 degrees.

6. Before starting to work, all persons who will operate the BAR GRADER must be familiar with all its functions and controls.

Attach the BAR GRADER according to the instructions on the tractor.

(Danger of injury!)

Before driving off, make sure you have a clear view both nearby and far away.

Safety stickers (Figs. 2, 3, 4) with the same meaning are present on both sides of the BAR GRADER (Fig. 5). Ensure these safety stickers are always clearly visible and legible. Replace them if they are damaged.

During operation, make sure there are **NO persons in the danger area** of the BAR GRADER to prevent them from getting injured by ejected material (Fig. 4).



Fig. 3



Fig. 4

Keep a distance of at least 4 metres! (Fig. 6).

Be aware of the maximum lifting capacity of the towing vehicle.

Wear suitable clothing. Wear sturdy shoes with a steel tip, wear long trousers, tie up long hair and do not wear loose clothing.

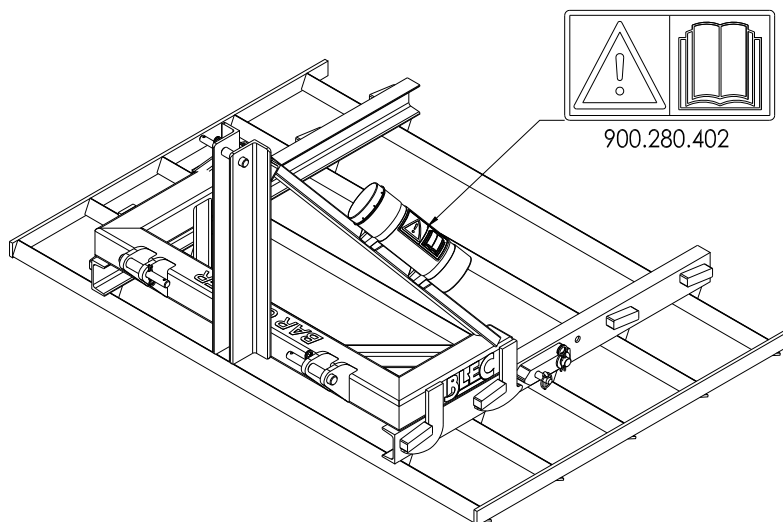

Fig. 5

(7) Location of safety stickers (Fig. 5).



EU DECLARATION

We,

Redexim BV
Utrechtseweg 127
3702 AC Zeist, Holland

declare – entirely on its own responsibility – that the product:

BAR GRADER WITH MACHINE NUMBER AS INDICATED ON THE MACHINE AND IN THIS MANUAL,

to which this declaration relates is according to the stipulation of the 2006/42/EC directive for machines.

Zeist,02 /06/16

A handwritten signature in blue ink, appearing to be 'A.C. Bos', written over a light blue rectangular background.

A.C. Bos
Manager Operations & Logistics
Redexim Holland

CONTENTS

USER MANUAL AND PARTS HANDBOOK	1
GUARANTEE CONDITIONS	2
REGISTRATION CARD	2
EU DECLARATION	6
1.0 TECHNICAL DATA	8
2.0 GENERAL DESCRIPTION	8
3.0 CONNECTING TO THE TRACTOR	9
4.0 REVERSING THE DRAG FRAME	10
5.0 TRANSPORTATION OF THE BAR GRADER	10
6.0 DRIVING SPEED.....	10
7.0 OPERATION OF THE BAR GRADER	11
8.0 STARTING/STOPPING PROCEDURE	11
9.0 DISCONNECTING THE BAR GRADER	12
10.0 TROUBLESHOOTING	13
11.0 MAINTENANCE	13

1.0 TECHNICAL DATA

<u>Model</u>	<u>BAR GRADER 180</u>	<u>BAR GRADER 240</u>
Working width	1.8 m (70.9")	2.4 m (94.5")
Bar Size	50x75x8	50x75x8
Driving speed	Max. 12 km/h (7.5 mph)	Max. 12 km/h (7.5 mph)
Hitch frame	CAT 1 - 2	CAT 1 - 2
Weight	182 kg (400.4 lbs)	202 kg (444.4 lbs)
Recommended tractor	20 HP with minimum lifting capacity of 250 kg (550 lbs)	40 HP with minimum lifting capacity of 300 kg (660 lbs)
Shipping dimensions L x W x H	1855 x 1335 x 900 mm (73" x 52.6" x 35.4")	2465 x 1335 x 900 mm (73" x 52.6" x 35.4")
Standard components	-Base frame -Drag frame -Toolbox including a manual	-Base frame -Drag frame -Toolbox including a manual

2.0 GENERAL DESCRIPTION

The BAR GRADER are ideal for grading soil and stoned areas quickly and easily.

3.0 CONNECTING TO THE TRACTOR

Inspection procedure before starting to connect the BAR GRADER.

- Visually inspect the BAR GRADER for signs of damage and repair them if they endanger the safe operation of the machine.
- Make sure that all nuts and bolts are properly tightened.
- Check whether all safety stickers are present and undamaged on the machine.
The machine may **NEVER** be used if this is not the case.

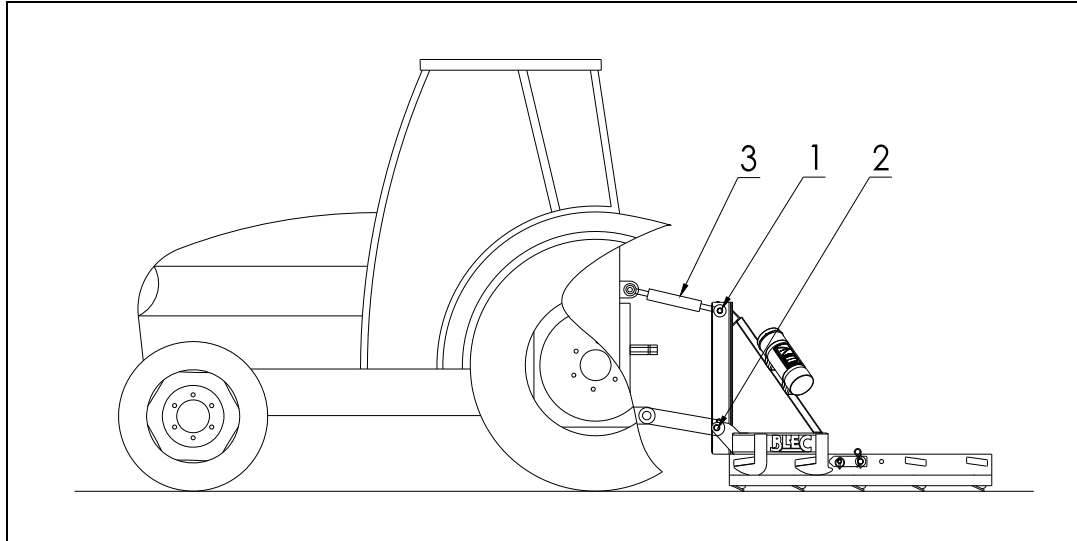

Fig. 8

The BAR GRADER can be connected to the tractor by means of the 3-point connection.

This is done as follows: (Fig 8.)

1. Drive the tractor carefully in reverse so that the low connection arms of the tractor can be connected to the frame.
⚠!! Ensure that the tractor is well blocked and cannot start moving by itself !!
⚠!! Switch the tractor off before dismounting !!
2. Connect the lower connection arms of the tractor to the 3-point connection pins 1 and secure them with the safety pins included.
3. Set the tractor's stabiliser to 100 mm of lateral movement.
4. Mount the top link 3 of your tractor and unscrew it until it has reached the same level as the 3-point stop connection of the BAR GRADER.
5. Connect the top rod 3 with pin 2 to the frame. Secure pin 2 using the safety pin included.
6. Make sure the BAR GRADER is level with the surface.
⚠!! Make sure that all mounting pins are securely locked!!
7. Start the tractor and raise the BAR GRADER from the ground..

4.0 REVERSING THE DRAG FRAME

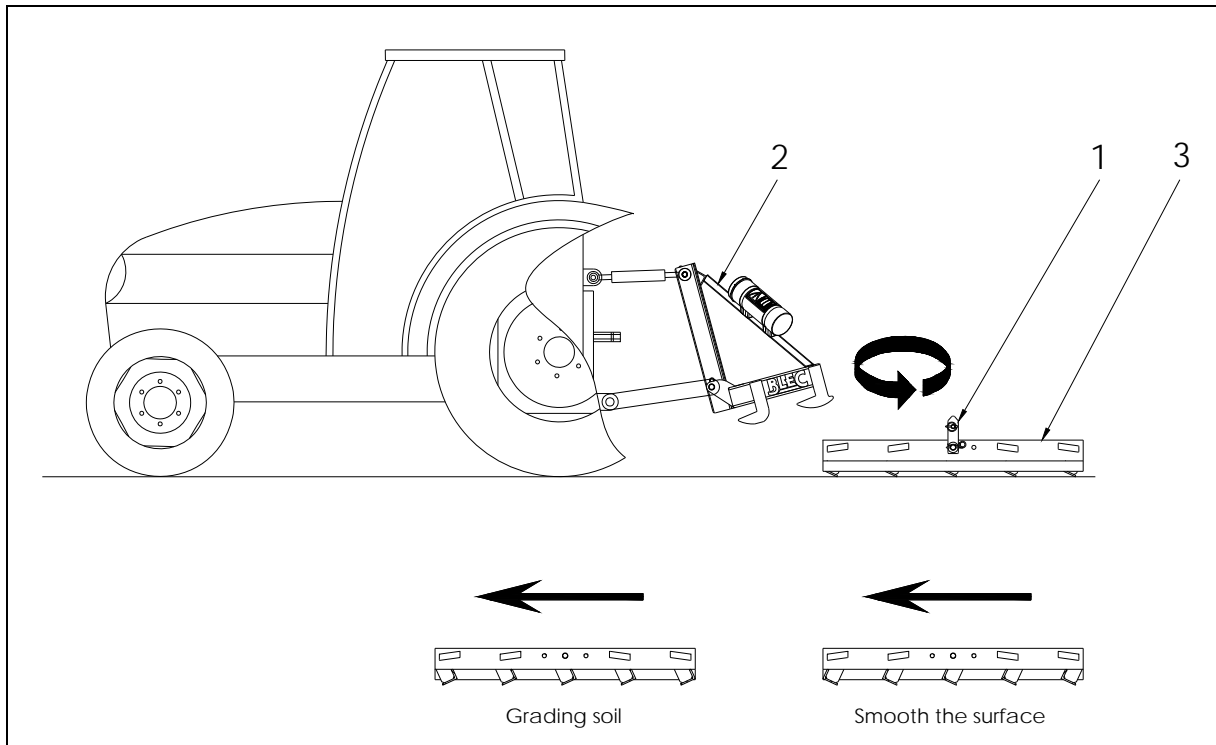

Fig. 9

The BAR GRADER can be used in two separate ways. The drag frame can be used forwards or backwards, proceed as follows (Fig.9):

1. Drive the machine to a flat surface and make sure the machine can't move or slide away.
2. Release 3-point pins 1 and unlock the locking bars on both sides of the machine.
3. Lift the quick hitch frame 2 on the tractor

⚠!! NEVER NOT CRAWL UNDER THE MACHINE !!

4. Rotate the drag frame 3 in the correct position
5. Lower the quick hitch frame 2 on the drag frame 3
6. Lock the drag frame 3 with locking bars and place the 3-point pins with secure pins 1

5.0 TRANSPORTATION OF THE BAR GRADER

The user is responsible for the transport of the Verti-Groom behind the tractor when travelling on public roads. Check the national traffic rules.

In view of the weight of the BAR GRADER, a maximum speed of 20 km/h (12.4 mph) should be observed while driving in open fields with the machine raised.

Higher speeds may endanger the driver and/or other people and even damage the machine.



When the machine is in the raised position, at least 20% of the weight of the tractor must be supported by the front axle.

6.0 DRIVING SPEED

The driving speed is limited to 12 km/h (7.5 mph).

Higher speeds are not recommended in view of excessive wear and damage that may occur to the machine and the ground underneath.

7.0 OPERATION OF THE BAR GRADER

Before the BAR GRADER is used in the field, the following must be checked:

1. Are there any slopes? The maximum slope this machine can work on is 20 degrees.
2. Is there any danger of sinking or sliding away? If so, delay the work until the conditions are more favourable.
3. A field can be done several times in the same direction or different directions to achieve better grading.
4. Do not make sharp turns; preferably drive in straight lines to avoid damaging the machine and/or the ground.

8.0 STARTING/STOPPING PROCEDURE

The starting procedure is **VERY** important. If this procedure is not followed exactly as described below, serious damage may occur to the ground underneath the machine.

The starting procedure is as follows:

1. Check the BAR GRADER thoroughly for loose parts and make sure all parts function properly.

!! If parts are found that are loose or do not function properly, correct the situation before using the BAR GRADER!!

2. Drive to the place where the ground is to be treated.
3. Lower the machine until it hangs approximately 50mm (2") above the ground so that the machine is at right angle to the ground.
4. Put the tractor in the correct gear.
5. Drive the tractor forward and lower the BAR GRADER smoothly .
6. Increase the driving speed to a maximum of 12 km/h (7.5 mph).

Stopping is done as follows:

1. While moving, raise the machine smoothly.
2. Drive to the following location and start again as described above.

9.0 DISCONNECTING THE BAR GRADER

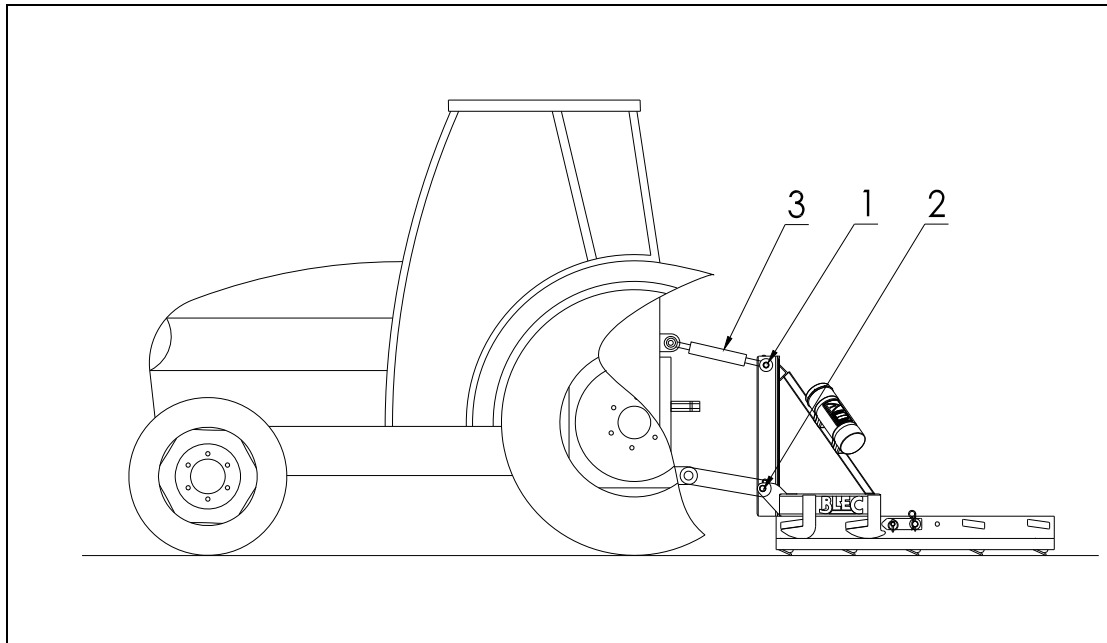

Fig. 10

The machine can be disconnected from the tractor as follows (see Fig 10):

1. Drive the BAR GRADER to its storage place, which must have a stable and flat ground.

⚠!! Ensure that the tractor is well blocked and cannot start moving by itself !!

⚠!! Switch the tractor off before dismounting !!

2. Lower the machine smoothly on the ground.
3. **⚠!! Make sure the BAR GRADER is stable and cannot slide away!!**
4. Remove the pin with safety pin and release the top link 3 .
5. Remove the pins with safety pins 2 and release the lower connection arms.
6. Start the tractor and drive it away from the machine.

When placing in storage, it is recommended to place the machine on wooden blocks.

10.0 TROUBLESHOOTING

Problem	Possible cause	Solution
<p><u>By grading;</u> Too little material loosened</p> <p>Poor appearance of field after completion.</p>	<p>Drag frame in the wrong position.</p> <p>Drag frame does not drag over the ground.</p> <p>Ground is to hard</p> <p>Drag frame does not drag over the ground.</p> <p>Ground is to hard</p>	<p>Rotate the drag frame in other position.</p> <p>Lower the drag frame</p> <p>Drive a few more passes in different directions</p> <p>Lower the drag frame</p> <p>Drive a few more passes in different directions</p>
<p><u>By smooth surfacing;</u> Ground too rough</p> <p>Poor appearance of field after completion.</p>	<p>Drag frame in the wrong position.</p> <p>Ground is to hard</p>	<p>Rotate the drag frame in other position.</p> <p>Drive a few more passes in different directions</p> <p>Frame not levelled</p>

11.0 MAINTENANCE

Time schedule	Check point/lubricating point	Method
Before <u>each</u> use	<p>Check for loose bolts/nuts.</p> <p>Presence and legibility of safety stickers (Fig. 5).</p>	<p>Tighten the loose bolts/nuts to the correct torque.</p> <p>Replace if damaged or missing.</p>